









-  Trackless System
-  Preset & Custom Massages
-  MyAquaFrixio Portal
-  Media Integrated
-  Smooth Zone Transition
-  Adjustable Water Temperature
-  Anti-Bacterial Top
-  Low & Easy Maintenance



- Electrical Rating:** 220V ~9A 60Hz
- Power Requirements:** 20 Amp Dedicated Line
- Water Requirements:** 40 Gallons Distilled Water
- Display:** 21" Touch Screen
- Session Time:** 10-60 Minutes
- TMAX Compatible:** Standard
- TMAX Integrated:** Optional (110V required)
- Weight:** 600 lbs filled
300 lbs empty
375 lbs weight limit

Room Size: 9 ft x 8 ft

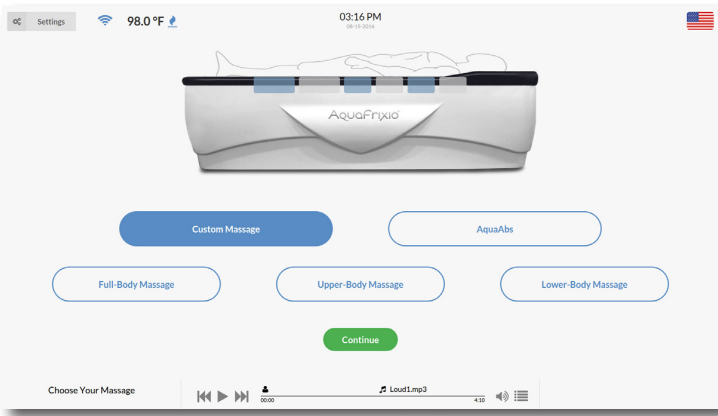
- ✓ All-In-One Internal Cooling System
- ✓ No Separate Room Needed
- ✓ Independently Operated

AquaFrixio Dimensions

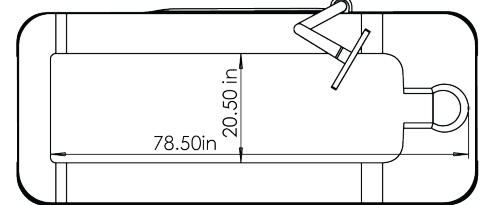
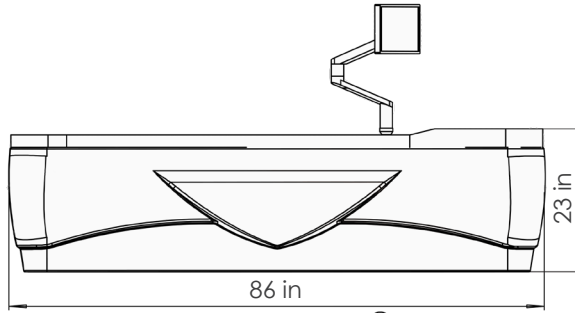
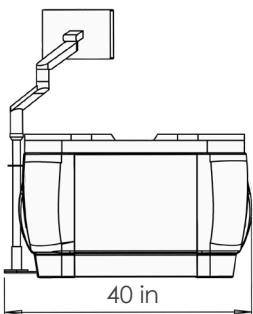

DISCLAIMER: A 0.50 KVA BUCKBOOSTER IS REQUIRED IF VOLTAGE IS BELOW 208V OR ABOVE 245V.

DISCLAIMER: UNIT REQUIRES DISTILLED WATER. USE OF NON-DISTILLED WATER VOIDS WARRANTY. DISTILLED WATER NOT INCLUDED.



800.874.2776 • Sales@prosun.com • ProSun.com

510(K): K181455

*ProSun reserves the right to change design and specifications without notice.